

H1600 Mechanical Overload Clutches HOR Series



Section Contents

FEATURES	36
OPERATING PRINCIPLES	36
SELECTION	37
HOW TO ORDER	37
RATINGS AND DIMENSIONS	38
MOUNTING HOLE PATTERNS	42
GENERAL INFORMATION	43

H1600 Overload Clutches HOR Series

Features

- Bi-directional operation
- Single position indexing
- Automatic reset
- Convenient torque adjustment
- Maximum torque limit stop
- Limit switch actuating mechanism
- Clamp collar for secure mounting
- Hardened components for long life
- Electroless nickel finish and stainless steel hardware for superior corrosion resistance
- Sealed from environmental contamination
- Interchanges POR Series
- Available in all Stainless upon request

Operating Principles

The HOR Series H1600 is an automatic reset ball detent style overload release clutch. It has been designed to provide accurate and dependable torque disconnect protection for mechanical power transmission equipment. Torque is transmitted through the clutch in one of two paths. Refer to Figure 1.

Figure 1

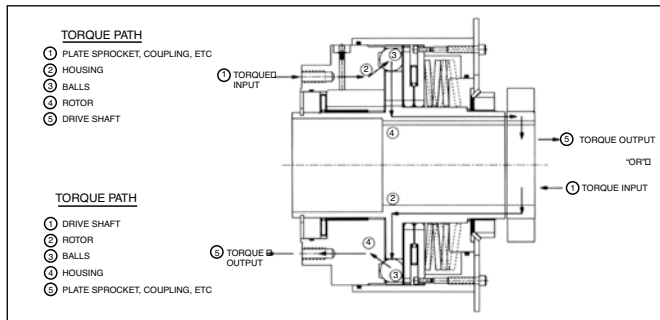

Torque transmission between the balls and housing is the key to the disengagement of the clutch. The balls are forced into the pockets of the housing by an axial load generated by compressing a spring pack. This axial load determines the torque capacity of the clutch. Increasing or decreasing the spring compression or changing spring packs provides a means for multiple torque adjustments. When a torque overload condition occurs, the balls roll out of the pockets and freewheel similar to a ball thrust bearing. This rolling action increases the efficiency in which the clutch operates and reduces any fluctuation of torque setting due to frictional changes. Refer to Figure 2.



The movement of the cover during disengagement can be used to trip a limit switch and signal a torque overload condition. The drive should be shut down immediately and the source of the overload determined and cleared. The drive can then be restarted. The automatic reset feature of the clutch will allow it to reengage without manual assistance and the clutch will once again be ready to provide accurate and dependable torque disconnect protection for your equipment.

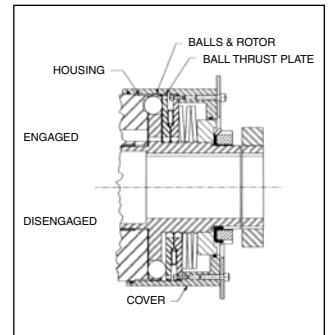

Figure 2

Torque Adjustment

The HOR Series H1600 Series Clutch can be factory set to your requirements. The torque setting of the clutch can easily be adjusted in the field to suit your needs. Two degrees of adjustment are available and described below.

Fine Adjustment: Lift the bearing lock washer tabs which secure the nut in position. Use a spanner wrench to adjust the bearing nut to your desired torque setting. Clockwise rotation will increase the torque and conversely, counterclockwise rotation will decrease the torque. Once the desired torque setting is made, fold the tab of the washer over the slot on the bearing nut to secure it in position at the new torque release level.

Coarse Adjustment: Large variations in torque setting can be accomplished by replacing the disc spring pack with that of a higher or lower spring rate. This change will effectively alter the load which can be applied to the balls.

H1600 Overload Clutches HOR Series

Selection

- Determine the overload release torque by one of these methods:
 - Use the torque formula with horsepower and RPM specific to the selected clutch location. A service factor may be required for high inertia starts, reversing or peak load conditions, (refer to Page 98 for service factor information. For average applications, a service factor "SF" of 1.25 is recommended):

$$\text{Torque (Lb. In.)} = \frac{\text{HP} \times 63025}{\text{RPM}} \times \text{SF}$$
 - Determine the "weak link" in the drive train, (i.e., chain, reducer, belt or shaft). Select an overload release torque below the "weak link's" maximum torque rating.
 - Physically measure the drive torque with a torque wrench and size accordingly.
- Determine the bore size(s) and keyway(s):
 - Shaft size at the clutch location determines clutch bore.
 - Shaft size at the coupling location determines coupling bore (if applicable).
- Choose the appropriate Style based upon the drive layout and available space (See Figure 3).
- Refer to the Basic Selection Chart for the appropriate clutch size.
- Refer to Part Numbering System to complete selection.

Figure 3

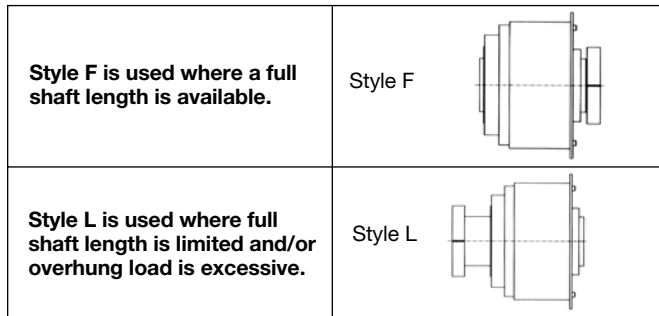

Basic Selection Chart

Clutch Size	Max. Bore* (In.)	Torque Code	Torque Range (Lb. In.)
02	F - 0.5625 L - 0.6875	L	25-60
		M	50-125
		H	75-175
		W	100-250
04	F - 1.1250 L - 1.2500	L	175-550
		M	250-850
		H	350-1,300
		W	600-2,000
05	F - 1.6250 L - 1.8125	L	350-1,200
		M	500-1,800
		H	750-2,600
		W	1,000-4,000
		Y	1,650-6,000
06	2.1250	L	600-1,900
		M	750-2,700
		H	1,000-3,800
		W	1,500-5,600
09	3.1250	L	2,250-7,500
		M	3,000-10,500
		H	4,250-15,000
		W	6,250-22,500
11	3.6250	L	6,000-22,000
		M	9,000-32,000
		H	12,000-50,000

*Maximum bores may require flat keys (supplied with unit).

How to Order

When ordering a HOR Series H1600 Overload Clutch, please include code letters/numbers for series, size, style, type, torque range, unit bore and coupling bore (if applicable).

Example:

Required size, 05 HOR Series H1600 Overload Clutch, standard style, flexible coupling, medium torque range, and a one inch bore on both the unit and coupling:

HOR **05** **F** **C** - **M** **P16** - **P16**

HOR Series Part Numbering System

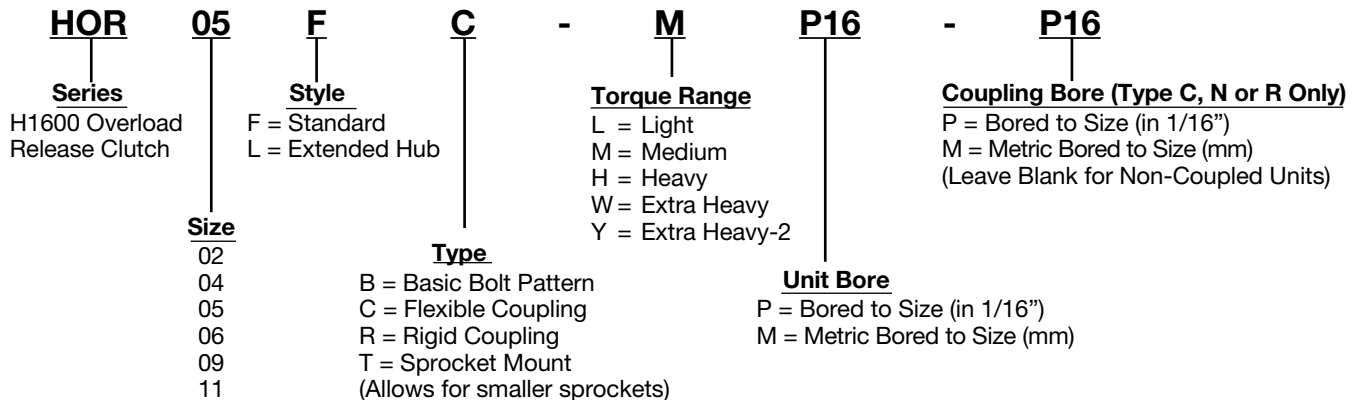

H1600 Overload Clutches HOR Series

Style F

Type B Basic Sprocket Mounting

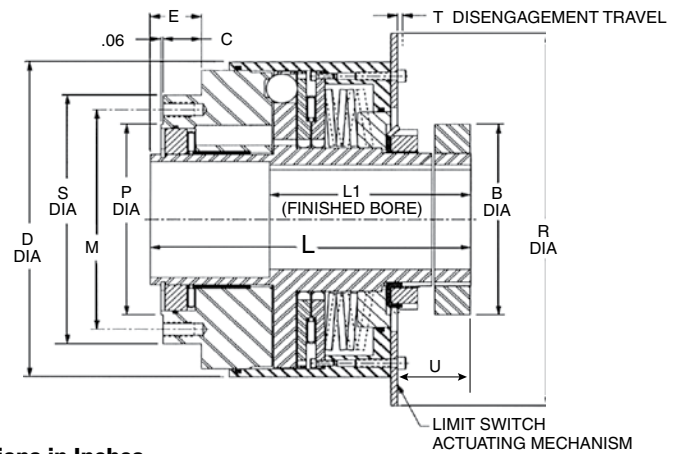
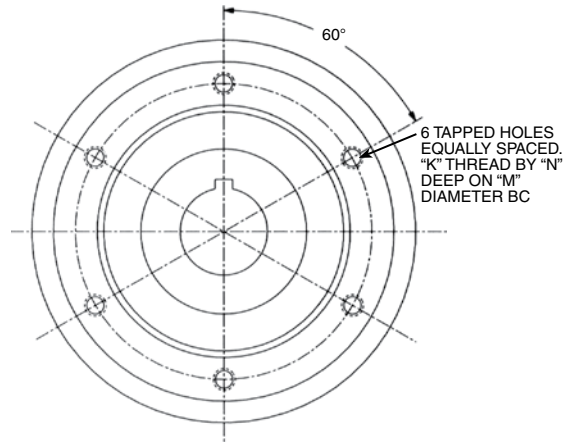

All Dimensions in Inches

Clutch Size	B	C	D	E	L	L1	P +0.000/-0.002	R	S	T	U	Mounting Holes		
												N	K	M
02	1.75	0.29	2.81	0.45	3.52	2.00	1.781	5.81	2.63	.060	.94	0.38	#8-32	2.125
04	2.38	0.35	4.25	0.56	4.79	3.00	2.688	7.25	3.63	.078	1.23	0.50	#10-24	3.062
05	3.50	0.43	5.88	0.70	6.20	3.88	3.625	8.88	5.00	.110	1.60	0.75	5/16-18	4.250
06	4.25	0.50	7.12	0.80	6.73	4.38	4.000	10.12	5.56	.128	1.71	0.81	3/8-16	4.750
09	5.75	1.03	9.50	1.40	9.00	5.50	5.750	12.50	7.56	.165	2.10	0.88	7/16-14	6.625
11	6.25	1.28	11.62	1.65	10.66	6.88	6.500	14.62	9.00	.183	2.69	1.00	5/8-11	7.750

Ratings

Clutch Size	Torque Range (Lb. In.)				Max. RPM	WR ² * (Lb.-In. ²)	Weight* (Lbs.)
	Code	Min.	MRT	Max.			
02	L	25	45	60	500	3.4	3.9
	M	50	100	125			
	H	75	125	175			
	W	100	200	250			
04	L	175	400	550	500	22.3	11.0
	M	250	600	850			
	H	350	850	1,300			
	W	600	1,400	2,000			
05	L	350	900	1,200	500	129	30.2
	M	500	1,300	1,800			
	H	750	1,800	2,600			
	W	1,000	2,750	4,000			
	Y	1,650	4,000	6,000			
06	L	600	1,400	1,900	500	266	43.3
	M	750	1,900	2,700			
	H	1,000	2,600	3,800			
	W	1,500	3,900	5,600			
	Y	2,800	7,000	10,000			
09	L	2,250	5,500	7,500	500	1,155	104
	M	3,000	7,500	10,500			
	H	4,250	10,000	15,000			
	W	6,250	15,000	22,500			
11	L	6,000	15,000	22,000	500	2,995	171
	M	9,000	20,000	32,000			
	H	12,000	30,000	50,000			

Clutch Bores

Clutch Size	Bores (inch)	
	Max. (1)	Max. (2)
02	0.5000	0.5625
04	1.0000	1.1250
05	1.5000	1.6250
06	1.9375	2.1250
09	2.8750	3.1250
11	3.1875	3.5000

Refer to Page 96 for a complete list of bore codes.

- (1) Square Key
- (2) Flat Key

Minimum Number of Teeth Adaptable to Type B Clutches

Clutch Size	Type	Standard Chain Size and Pitch						
		#25 1/4 Pitch	#35 3/8 Pitch	#40 1/2 Pitch	#50 5/8 Pitch	#60 3/4 Pitch	#80 1 Pitch	#100 1-1/4 Pitch
02	B	39	27	22	—	—	—	—
04	B	51	35	28	23	—	—	—
05	B	69	47	36	30	26	—	—
06	B	76	52	40	33	28	—	—
09	B	101	68	52	43	36	28	24
11	B	119	80	61	50	43	33	27

*Weight and WR² estimated with maximum bores.
MRT is the Minimum Recommended Torque setting for those applications which require a minimal degree of backlash.
Clutches are shipped set for the minimum torque value of the selected range.
Refer to Page 37 for ordering information.

H1600 Overload Clutches HOR Series

Style L Extended Hub Type B Basic Sprocket Mounting

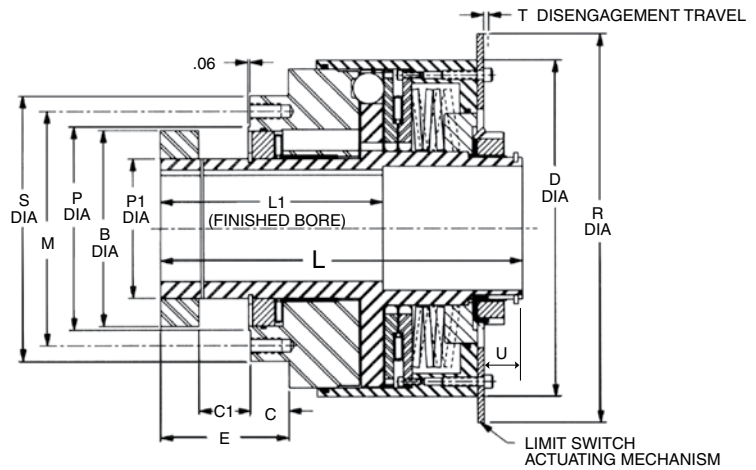
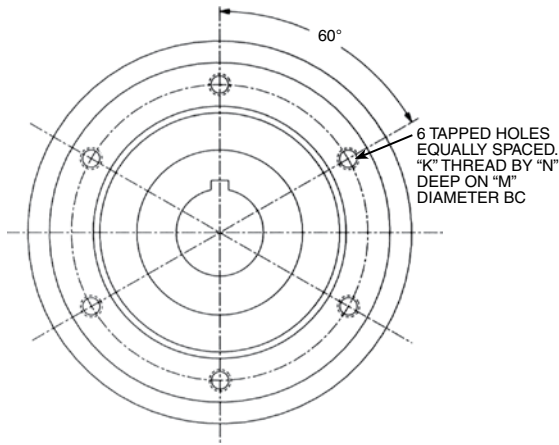

All Dimensions in Inches

Clutch Size	B	C	C1	D	E	L	L1	P +0.000/-0.002	P1		R	S	T	U	Mounting Holes		
									Min.	Max.					N	K	M
02	1.75	0.29	1.25	2.81	2.04	4.63	3.25	1.781	0.9843	0.9847	5.81	2.63	.060	.45	0.38	#8-32	2.125
04	2.38	0.35	1.44	4.25	2.35	6.06	3.88	2.688	1.5728	1.5738	7.25	3.63	.078	.74	0.50	#10-24	3.062
05	3.50	0.43	2.06	5.88	3.24	8.18	5.25	3.625	2.3623	2.3628	8.88	5.00	.110	1.06	0.75	5/16-18	4.250
06	4.25	0.50	3.62	7.12	4.87	10.25	6.88	4.000	2.7560	2.7566	10.12	5.56	.128	1.15	0.81	3/8-16	4.750
09	5.75	1.03	4.25	9.50	6.28	13.23	9.00	5.750	3.9350	3.9370	12.50	7.56	.165	1.50	0.88	7/16-14	6.625
11	6.50	1.28	4.50	11.62	7.16	15.01	10.00	6.500	4.7220	4.7240	14.62	9.00	.183	1.54	1.00	5/8-11	7.750

Ratings

Clutch Size	Torque Range (Lb. In.)				Max. RPM	WR ² * (Lb.-In. ²)	Weight* (Lbs.)
	Code	Min.	MRT	Max.			
02	L	25	45	60	500	3.5	4.0
	M	50	100	125			
	H	75	125	175			
	W	100	200	250			
04	L	175	400	550	500	22.4	11.5
	M	250	600	850			
	H	350	850	1,300			
	W	600	1,400	2,000			
05	L	350	900	1,200	500	130	31.7
	M	500	1,300	1,800			
	H	750	1,800	2,600			
	W	1,000	2,750	4,000			
06	L	600	1,400	1,900	500	270	47.0
	M	750	1,900	2,700			
	H	1,000	2,600	3,800			
	W	1,500	3,900	5,600			
09	L	2,250	5,500	7,500	500	1,180	112
	M	3,000	7,500	10,500			
	H	4,250	10,000	15,000			
	W	6,250	15,000	22,500			
11	L	6,000	15,000	22,000	500	3,040	182
	M	9,000	20,000	32,000			
	H	12,000	30,000	50,000			

Clutch Bores

Clutch Size	Bores (inch)	
	Max. (1)	Max. (2)
02	0.6250	0.6875
04	1.1250	1.2500
05	1.7500	1.8125
06	1.9375	2.1250
09	2.8750	3.1250
11	3.2500	3.6250

Refer to Page 96 for a complete list of bore codes.

- (1) Square Key
- (2) Flat Key

Minimum Number of Teeth Adaptable to Type B Clutches

Clutch Size	Type	Standard Chain Size and Pitch						
		#25	#35	#40	#50	#60	#80	#100
		1/4 Pitch	3/8 Pitch	1/2 Pitch	5/8 Pitch	3/4 Pitch	1 Pitch	1-1/4 Pitch
02	B	39	27	22	—	—	—	—
04	B	51	35	28	23	—	—	—
05	B	69	47	36	30	26	—	—
06	B	76	52	40	33	28	—	—
09	B	101	68	52	43	36	28	24
11	B	119	80	61	50	43	33	27

*Weight and WR² estimated with maximum bores.

MRT is the Minimum Recommended Torque setting for those applications which require a minimal degree of backlash.

Clutches are shipped set for the minimum torque value of the selected range.

Refer to Page 37 for ordering information.

H1600 Overload Clutches HOR Series

Style F

Type C Flexible Coupling

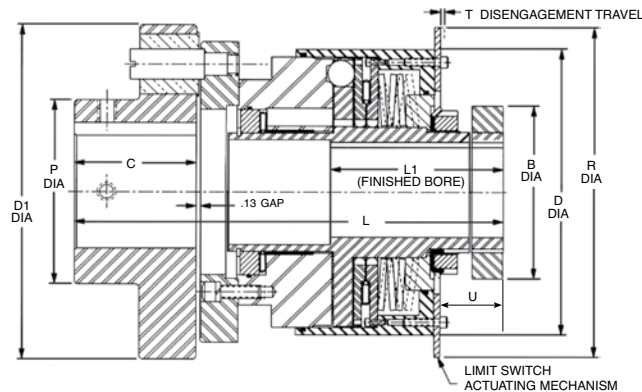

All Dimensions in Inches

Clutch Size	B	C	D	D1	L	L1	P	R	T	U	Max. Allowable Misalignment*	
											Parallel*	Angular*
02	1.75	1.25	2.81	3.94	5.50	2.00	2.50	5.81	.060	.94	.012	1°
04	2.38	1.25	4.25	5.13	6.64	3.00	3.25	7.25	.078	1.23	.016	1°
05	3.50	2.38	5.88	6.88	9.94	3.88	3.88	8.88	.110	1.60	.027	1°
06	4.25	2.88	7.12	8.13	11.25	4.38	4.25	10.12	.128	1.71	.045	1°
09	5.75	4.00	9.50	11.13	14.52	5.50	6.12	12.50	.165	2.10	.045	1°
11	6.25	4.50	11.62	14.00	16.67	6.88	7.50	14.62	.183	2.69	.045	1°

*Parallel and Angular misalignment are proportionally reduced when both are present.

Ratings

Clutch Size	Torque Range (Lb. In.)				Max. RPM	WR ² * (Lb.-In. ²)	Weight* (Lbs.)
	Code	Min.	MRT	Max.			
02	L	25	45	60	500	10.0	8.0
	M	50	100	125			
	H	75	125	175			
	W	100	200	250			
04	L	175	400	550	500	44.0	18.0
	M	250	600	850			
	H	350	850	1,300			
	W	600	1,400	2,000			
05	L	350	900	1,200	500	241	49.0
	M	500	1,300	1,800			
	H	750	1,800	2,600			
	W	1,000	2,750	4,000			
	Y	1,650	4,000	6,000			
06	L	600	1,400	1,900	500	550	82.0
	M	750	1,900	2,700			
	H	1,000	2,600	3,800			
	W	1,500	3,900	5,600			
	Y	2,800	7,000	10,000			
09	L	2,250	5,500	7,500	500	2,325	180
	M	3,000	7,500	10,500			
	H	4,250	10,000	15,000			
	W	6,250	15,000	22,500			
11	L	6,000	15,000	22,000	500	6,215	305
	M	9,000	20,000	32,000			
	H	12,000	30,000	50,000			

*Weight and WR² estimated with maximum bores.
MRT is the Minimum Recommended Torque setting for those applications which require a minimal degree of backlash.
Clutches are shipped set for the minimum torque value of the selected range.
Refer to Page 37 for ordering information.

Clutch and Coupling Bores

Clutch Size	Type	Bores	
		Max. (1)	Max. (2)
02	Clutch	0.5000	0.5625
	Coupling	1.1875	-
04	Clutch	1.0000	1.1250
	Coupling	1.8750	-
05	Clutch	1.5000	1.6250
	Coupling	2.3125	2.3750
06	Clutch	1.9375	2.1250
	Coupling	2.6250	2.7500
09	Clutch	2.8750	3.1250
	Coupling	4.0000	4.1250
11	Clutch	3.1875	3.5000
	Coupling	4.6250	5.0000

Refer to Page 96 for a complete list of bore codes.
(1) Square Key
(2) Flat Key

H1600 Overload Clutches HOR Series

Style F Type R Rigid Coupling

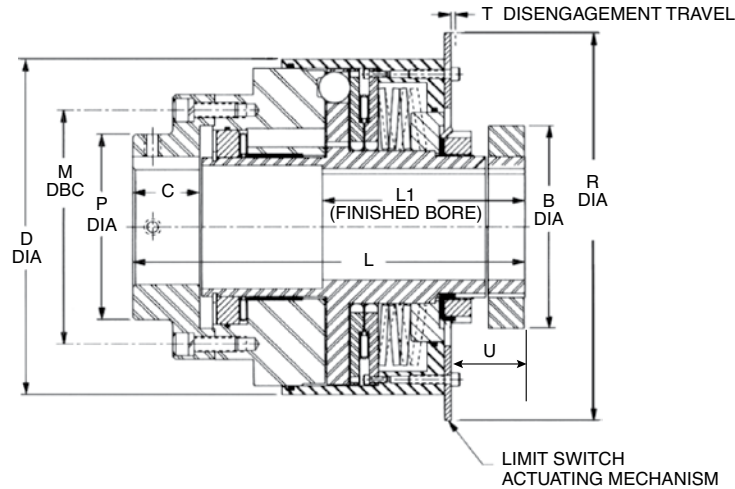

All Dimensions in Inches

Clutch Size	B	C	D	L	L1	M	P	R	T	U
02	1.75	0.75	2.81	4.36	2.00	2.125	1.38	5.81	.060	.94
04	2.38	1.62	4.25	6.51	3.00	3.062	2.50	7.25	.078	1.23
05	3.50	2.13	5.88	8.43	3.88	4.250	3.31	8.88	.110	1.60
06	4.25	2.20	7.12	9.02	4.38	4.750	3.50	10.12	.128	1.71
09	5.75	3.34	9.50	12.43	5.50	6.625	5.25	12.50	.165	2.10
11	6.25	3.96	11.62	14.77	6.88	7.750	6.00	14.62	.183	2.69

Ratings

Clutch Size	Torque Range (Lb. In.)			Max. RPM	WR ^{2*} (Lb.-In. ²)	Weight* (Lbs.)	
	Code	Min.	MRT				Max.
02	L	25	45	60	500	4.1	4.7
	M	50	100	125			
	H	75	125	175			
	W	100	200	250			
04	L	175	400	550	500	26.3	13.3
	M	250	600	850			
	H	350	850	1,300			
	W	600	1,400	2,000			
05	L	350	900	1,200	500	146	35.5
	M	500	1,300	1,800			
	H	750	1,800	2,600			
	W	1,000	2,750	4,000			
	Y	1,650	4,000	6,000			
06	L	600	1,400	1,900	500	296	50.9
	M	750	1,900	2,700			
	H	1,000	2,600	3,800			
	W	1,500	3,900	5,600			
	Y	2,800	7,000	10,000			
09	L	2,250	5,500	7,500	500	1,295	124
	M	3,000	7,500	10,500			
	H	4,250	10,000	15,000			
	W	6,250	15,000	22,500			
11	L	6,000	15,000	22,000	500	3,290	200
	M	9,000	20,000	32,000			
	H	12,000	30,000	50,000			

Clutch and Coupling Bores

Clutch Size	Type	Bores	
		Max. (1)	Max. (2)
02	Clutch	0.5000	0.5625
	Coupling	0.7500	-
04	Clutch	1.0000	1.1250
	Coupling	1.6250	1.6875
05	Clutch	1.5000	1.6250
	Coupling	2.1250	2.2500
06	Clutch	1.9375	2.1250
	Coupling	2.2500	2.3125
09	Clutch	2.8750	3.1250
	Coupling	3.3750	3.5000
11	Clutch	3.1875	3.5000
	Coupling	4.0000	4.1250

Refer to Page 96 for a complete list of bore codes.

- (1) Square Key
- (2) Flat Key

*Weight and WR² estimated with maximum bores.
MRT is the Minimum Recommended Torque setting for those applications which require a minimal degree of backlash.
Clutches are shipped set for the minimum torque value of the selected range.
[Refer to Page 37 for ordering information.](#)

H1600 Overload Clutches HOR Series

Type T Adapter Mounts to Existing Housing Bolt Pattern

Type T Sprocket, Pulley, Sheave or Gear Mount

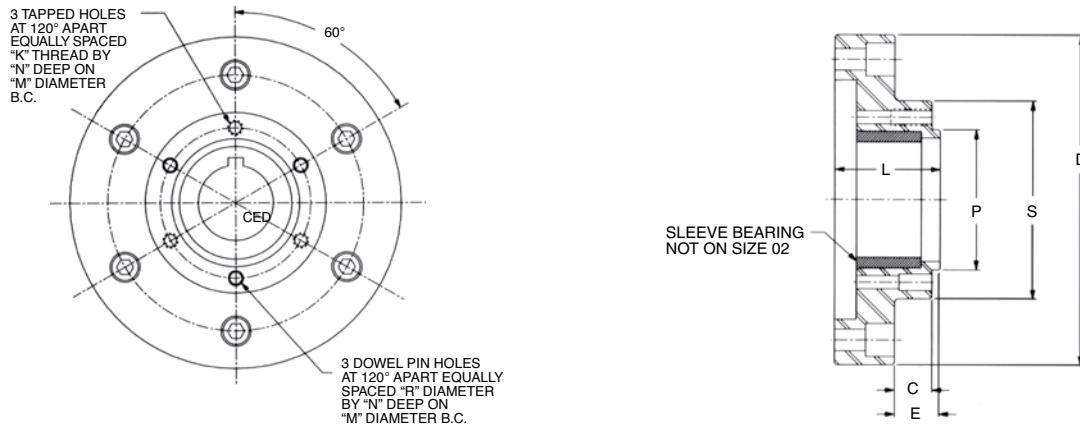

All Dimensions in Inches

Clutch Size	C	D	E	K	L	M	N	P +0.000/-0.002	R	S	WR ² (Lb.-In. ²)	Weight (Lbs.)
02	0.28	2.63	0.40	#8-32	0.71	1.422	.38	1.094	—	1.75	0.5	0.5
04	0.34	3.63	0.63	#8-32	1.02	2.250	.38	1.922	3/16	2.58	2.0	1.0
05	0.47	5.00	0.59	1/4-20	1.26	3.219	.50	2.750	1/4	3.66	12	3.0
06	0.69	5.56	0.81	1/4-20	1.55	3.406	.50	2.938	1/4	3.90	25	5.4
09	0.88	7.56	1.00	3/8-16	2.00	5.094	.75	4.344	3/8	5.84	93	11
11	1.02	9.00	1.14	3/8-16	2.32	5.938	.75	5.188	1/2	6.69	241	19

Mounting bolts must be minimum 160,000 PSI tensile, Rc 36-43

Dowel pins must be minimum 150,000 PSI shear, Rc 50-58 core hardness

Minimum Number of Teeth Adaptable to Type T Clutches Type T Clutches Allow for the Use of Smaller Sprockets

Clutch Size	Type	Standard Chain Size and Pitch						
		#25 1/4 Pitch	#35 3/8 Pitch	#40 1/2 Pitch	#50 5/8 Pitch	#60 3/4 Pitch	#80 1 Pitch	#100 1-1/4 Pitch
02	T	27	19	15	—	—	—	—
04	T	37	26	20	17	—	—	—
05	T	50	35	27	23	19	—	—
06	T	54	37	29	24	20	16	14
09	T	79	54	41	34	29	23	19
11	T	90	61	47	38	32	25	21

The Type T adapter may be ordered separately or factory mounted to the HOR Series Clutches shown on Pages 38 and 39, by specifying Type T.

Torque Adjustment Wrench

Standard bearing nuts are used to adjust the spring load which controls the release torque of the clutch. These nuts are slotted and can easily be turned using a common, commercially available hook style spanner wrench. Refer to the table below for wrenches which are compatible with Boston Gear's torque overload release clutches.

Torque Adjustment Wrench

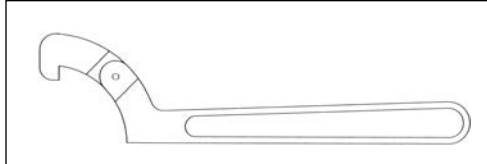

Clutch Size	Wrench Part Number				Specifications (Inches)			
	Armstrong Tool Co.	McMaster-Carr Supply Co.	Williams Tool Co.	Snap-On Tool Co.	Diameter Range	Hook Thick.	Hook Depth	Length
02	34-301	5471A11	471	AHS300	.75 to 2.00	.34	.13	6.38
02, 04	34-304	5471A12	472	AHS301	1.25 to 3.00	.41	.16	8.13
04, 05, 06	34-307	5471A13	474	AHS304	2.00 to 4.75	.47	.19	11.38
09, 11	34-310	5471A14	474A	AHS307	4.50 to 6.25	.47	.25	12.13
11	34-313	5471A23	474B	—	6.12 to 8.75	.47	.31	13.75

Torque Overload Detection

The HOR Series H1600 Clutch is an automatic reset device designed for use when a fully disconnecting type is not desirable either because it is inaccessible and cannot be manually reset or because frequent resetting is not feasible. Because of this feature, it is important that the drive be shut down immediately upon a torque overload condition to prevent possible damage to the clutch caused by long-term reengaging and disengaging. Figure 4 utilizes a single limit switch to detect an overload condition. The switch should be able to operate within the disengagement travel of the clutch. Upon an overload, the cover of the clutch will move to actuate the limit switch and shut down the drive. The switch should be wired in parallel with a jog button so the drive can be indexed and permit the clutch to reengage at a safe speed. Once the clutch has been reengaged the limit switch will be reset and the drive can be restarted.

Figure 4
Limit Switch Layout

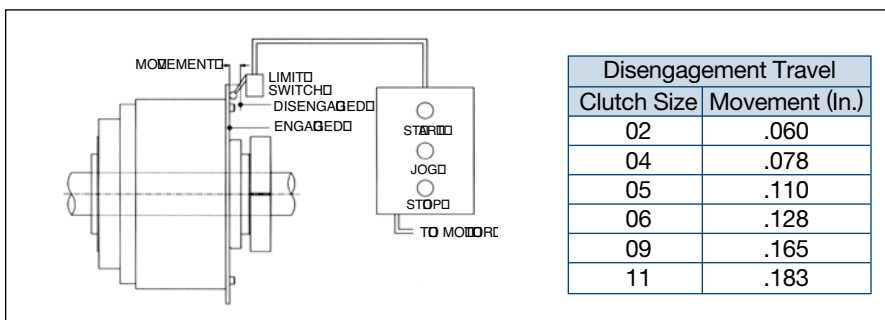
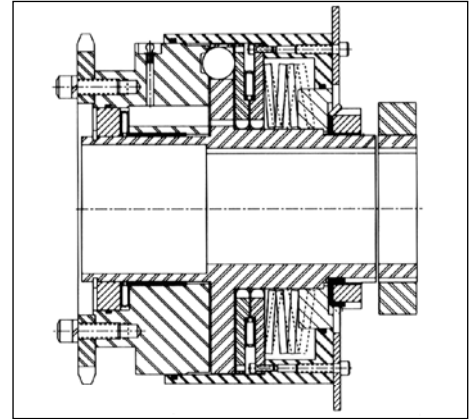
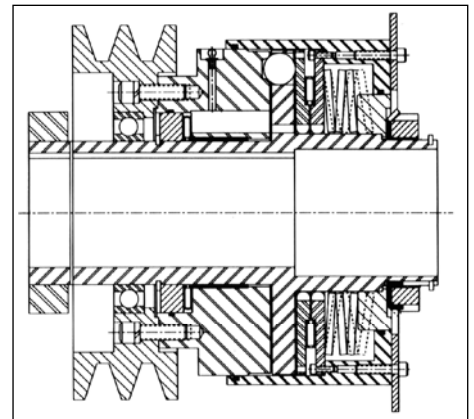

Figure 5
Suggested Mounting Arrangements



Type B, Style F
with Sprocket Mounted



Type B, Style L
with Sheave Mounted

H1600 Overload Clutches

Torque Limiter Application Data

Fax To 800-816-5608

Please select your product intent below and provide as much application information as possible.

1. Application:

- New
- Existing
- Replacement Model # _____

2. Power transmission requirements at clutch location:

- RPM _____
- Limiting Torque Level _____

3. Type:

- Mechanical (Spring Loaded)
- Pneumatic

4. Type:

- Fully Automatic Re-Engagement
- Manual (Free Wheeling)
- Semi Automatic (ORC model only)

5. Method of Torque Transmission:

- Flexible Coupling
- Rigid Coupling
- Sprocket Mount

Sprocket Size and Tooth Count _____

6. Bore Size:

- Sprocket Mount (Clutch Bore) _____
- Coupling Mount (Clutch Bore) _____
(Coupling Bore) _____

7. Shut Down Method:

- Prox Plate
- Pin Style (ORC only)
- None Required

Name: _____

Phone # _____

Fax # _____

Company _____

E-Mail _____

Use the space below to note any relevant application data or to detail your question.

H1900 Mechanical Overload Clutches WOR Series

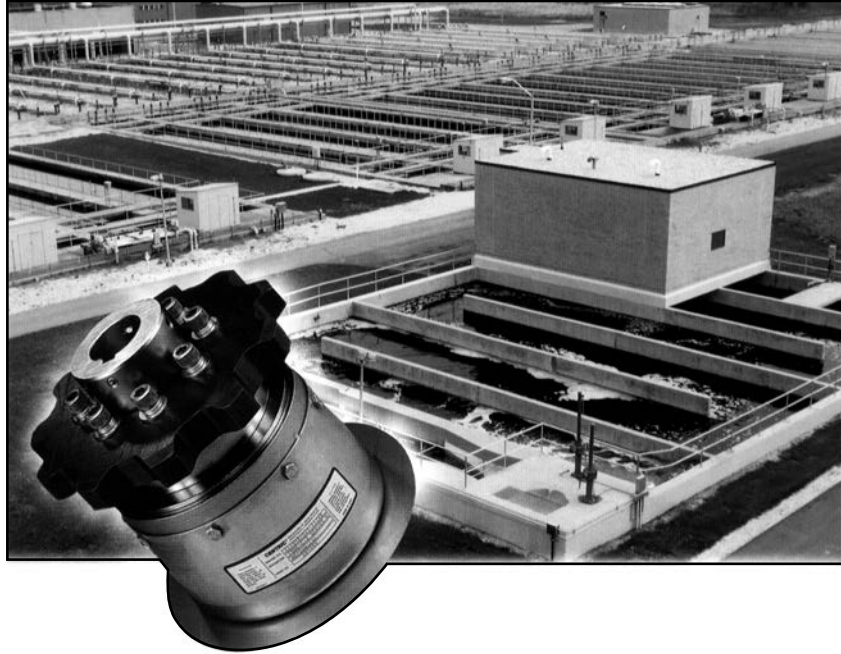

Designed for the water and wastewater industry

Section Contents

FEATURES	46
OPERATING PRINCIPLES	46
SELECTION	47
HOW TO ORDER.....	47
RATINGS AND DIMENSIONS	48
GENERAL INFORMATION	51
SUGGESTED SPECIFICATIONS.....	51

H1900 Overload Clutches Waste Water Industry WOR Series

Features

- Automatic or manual reset
- Large bore capacity
- Through shaft or end shaft mounting
- Accurate torque release
- Stainless steel enclosure
- Electroless nickel plated
- Adaptable for all drives
- Operating parts are hardened for long life

Operating Principles

The WOR Series H1900 is a mechanical ball detent overload release clutch. It has been designed to provide accurate and dependable torque overload protection for mechanical water and wastewater treatment equipment.

Torque is transmitted between the balls and the detents of the rotor in the following manner:

The chrome alloy balls are forced into the detents of the 50 Rc hardened rotor by an axial load generated by compressing a spring pack. This axial load is what determines the torque capacity of the clutch. Increasing or decreasing the spring compression or changing spring packs provides a means for multiple torque adjustments. When a torque overload condition occurs, the balls roll out of the rotor detents. This rolling action reduces any fluctuation in torque due to frictional changes (See Figure 1).

The movement of the cover during disengagement of the balls can be used to trip a limit switch and signal an overload condition. The drive should be shut down immediately and the source of the overload determined and cleared. After the clutch has been reset the drive can then be restarted.

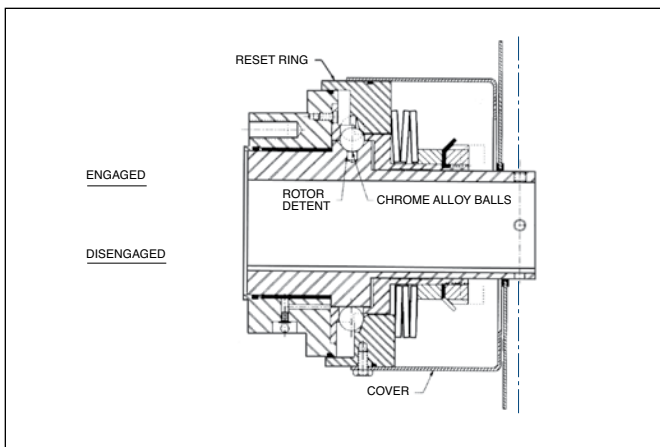

Figure 1



The **Manual Reset** (Style M or N) clutch can be reset in multiple positions. Rotate the drive until a lube fitting or a barring hole on the housing lines up with a tapped hole on the rotor. The rotor keyway should also be lined up with a lube fitting on the housing. After the proper position has been established, push evenly on both sides of the limit switch actuating plate. When the clutch is properly reset, the steel balls will move back into their detents and the actuating plate will return to its original position. An audible sound will be detected when the clutch re-engages, (See Figure 2).

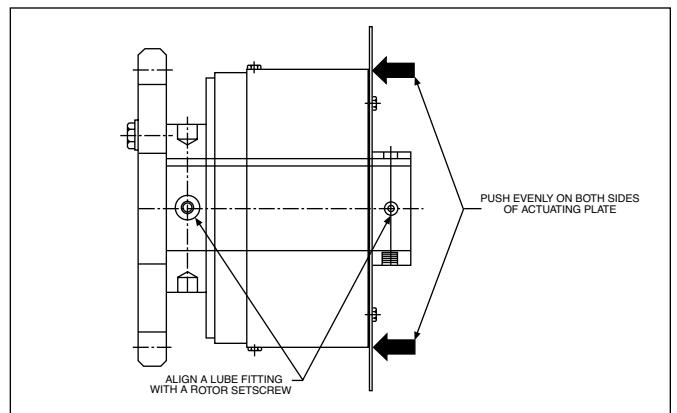

Figure 2

The **Automatic Reset** (Style A or B) version will re-engage without manual assistance. The steel balls will move back into their pockets every 1/4 of a revolution (1/8 of a revolution on the Size 11). After the overload condition has been cleared, jog the drive until the balls return to their detents and the actuating plate returns to its original position. An audible sound will be detected when the clutch re-engages.

H1900 Overload Clutches

Selection

1. Determine the overload release torque by one of these methods:

- Use the torque formula with horsepower and RPM specific to selected clutch location. A service factor may be required for high inertia starts, reversing or peak load conditions, (refer to Page 98 for service factor information. For average applications, a service factor "SF" of 1.25 is recommended):

$$\text{Torque (Lb. In.)} = \frac{\text{HP} \times 63025}{\text{RPM}} \times \text{SF}$$

- Maximum drive torque of chain: If using non-metallic chain, contact the manufacturer of the chain and ask for its maximum drive torque.
 - For shear pin replacement: Contact your local Boston Gear Area Sales Manager or the factory. They will gladly calculate the shear torque of your existing shear pins for you.
2. Determine the bore size and keyway.
3. Choose the proper style from Figures 3, 4, or 5 based upon the drive layout.
4. Refer to the Basic Selection Chart for the appropriate clutch size.

Basic Selection Chart

Size	Torque Code	Torque Range (Lb.-In.)		Maximum Bore (In.)*	
		Minimum	Maximum	Style A/M	Style B/N
05	L	850	1,700	1.7500	2.0000
	M	1,100	2,200		
	H	1,400	2,800		
	W	2,500	5,000		
06	L	1,250	2,500	2.2500	2.7500
	M	1,800	3,750		
	H	2,500	5,500		
	W	4,000	8,000		
09	L	2,250	5,750	3.0000	4.2500
	M	3,750	8,500		
	H	5,500	12,000		
	W	8,500	20,000		
11	L	5,000	12,000	4.0000	4.2500
	M	9,000	16,500		
	H	12,000	25,000		
	W	16,000	30,000		

*Larger bores may require flat keys (supplied with unit).

Figure 3

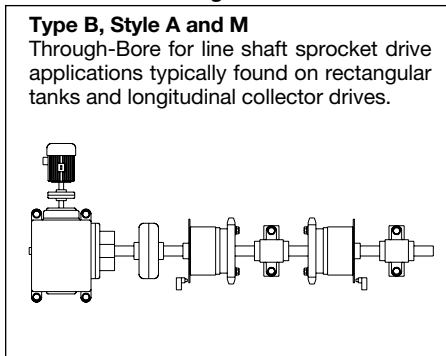

Figure 4

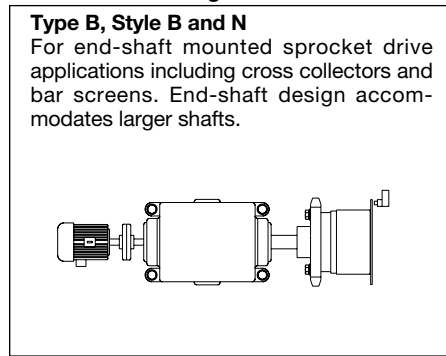
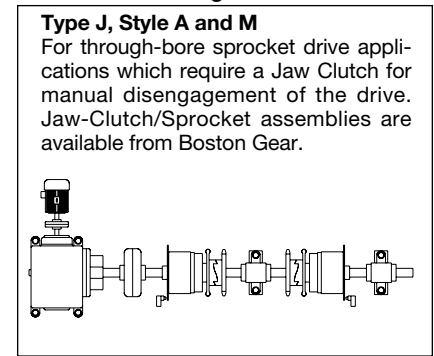

Figure 5



WOR Series Part Numbering System

WOR

Series
Wastewater
Overload
Release
Clutch

05

Size
05
06
09
11

A

Style
A = Automatic Reset Through Bore
B = Automatic Reset End Shaft
M = Manual Reset Through Bore
N = Manual Reset End Shaft

B

Type
B = Basic Bolt Pattern
J = Jaw

-

L

Torque Range
L = Light
M = Medium
H = Heavy
W = Extra Heavy

P16

Unit Bore

P = Bored to Size (in 1/16")
M = Metric Bored to Size (mm)

How to Order

When ordering a WOR Series H1900 Overload Clutch for Wastewater Treatment applications, please include code letters/numbers for series, size, style, type, torque range, and bore size.

Example:

Required size, 05 WOR Series H1900 Overload Clutch, automatic reset, through-bore mounting, basic type, medium torque range, with a one inch bore:

WOR 05 A B — M P16

H1900 Overload Clutches WOR Series

Style A and M Through-Bore Type B Basic Sprocket Mounting

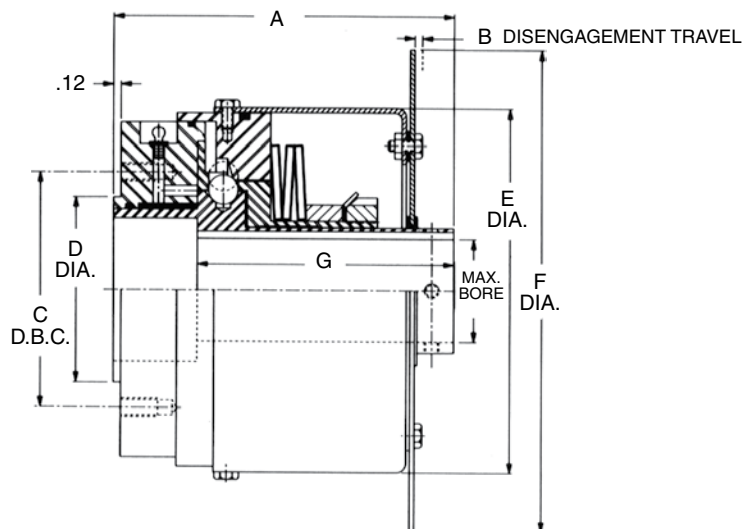

All Dimensions in Inches

Clutch Size	A	B	C	D +0.000/-0.002	E	F	G	Mounting Holes			Min. H78 Sprocket
								No.	Thread	Depth	
05	5.76	.13	4.000	3.123	6.19	8.19	4.50	6	5/16-18	0.75	9 Tooth
06	7.45	.17	4.875	4.000	7.62	9.62	5.25	8	1/2-13	1.12	9 Tooth
09	9.14	.19	4.875	4.000	9.65	11.62	6.12	8	1/2-13	1.25	9 Tooth
11	10.00	.19	6.500	5.500	9.65	11.62	7.00	8	1/2-13	1.25	11 Tooth

Ratings

Clutch Size	Torque Code	Torque Range (Lb. In.)		Max. RPM	Weight (Lbs.)
		Min.	Max.		
05	L	850	1,700	50	24
	M	1,100	2,200		
	H	1,400	2,800		
	W	2,500	5,000		
06	L	1,250	2,500	50	40
	M	1,800	3,750		
	H	2,500	5,500		
	W	4,000	8,000		
09	L	2,250	5,750	50	80
	M	3,750	8,500		
	H	5,500	12,000		
	W	8,500	20,000		
11	L	5,000	12,000	50	87
	M	9,000	16,500		
	H	12,000	25,000		
	W	16,000	30,000		

Clutch Bores

Clutch Size	Bores (inch)		
	Min.	Max. (1)	Max. (2)
05	0.6250	1.6250	1.7500
06	0.6250	2.1250	2.2500
09	1.0000	2.7500	3.0000
11	1.0000	3.7500	4.0000

Refer to Page 96 for a complete list of bore codes.

- (1) Square Key
- (2) Flat Key

Clutches are shipped set for the minimum torque value of the specified range.

Refer to Page 47 for ordering information.

H1900 Overload Clutches WOR Series

Style B and N End-Shaft Type B Basic Sprocket Mounting

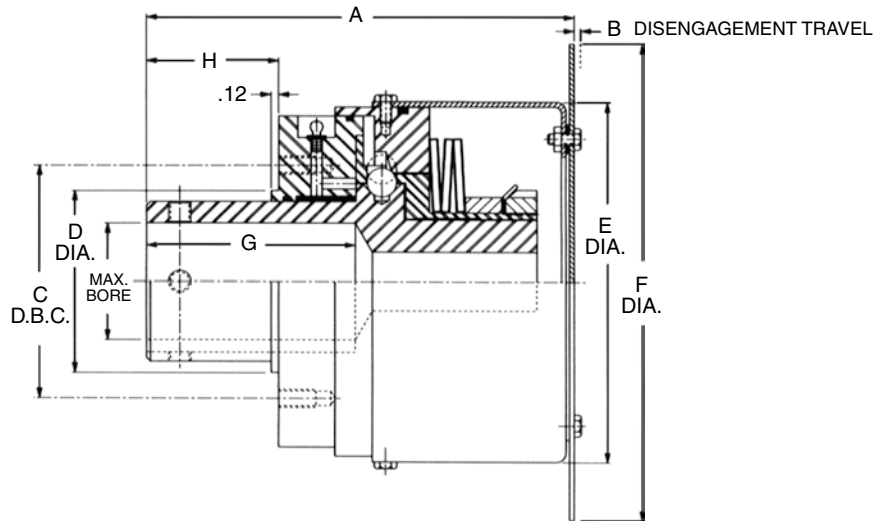

All Dimensions in Inches

Clutch Size	A	B	C	D +0.000/-0.002	E	F	G	H	Mounting Holes			Min. H78 Sprocket
									No.	Thread	Depth	
05	7.00	0.13	4.000	3.123	6.19	8.19	3.30	2.09	6	5/16-18	0.75	9 Tooth
06	9.04	0.17	4.875	4.000	7.62	9.62	4.69	2.56	8	1/2-13	1.12	9 Tooth
09	10.75	0.19	6.500	5.500	9.65	11.62	5.88	3.00	8	1/2-13	1.25	11 Tooth
11	11.44	0.19	6.500	5.500	9.65	11.62	5.88	3.00	8	1/2-13	1.25	11 Tooth

Ratings

Clutch Size	Torque Code	Torque Range (Lb. In.)		Max. RPM	Weight (Lbs.)
		Min.	Max.		
05	L	850	1,700	50	25
	M	1,100	2,200		
	H	1,400	2,800		
	W	2,500	5,000		
06	L	1,250	2,500	50	42
	M	1,800	3,750		
	H	2,500	5,500		
	W	4,000	8,000		
09	L	2,250	5,750	50	83
	M	3,750	8,500		
	H	5,500	12,000		
	W	8,500	20,000		
11	L	5,000	12,000	50	87
	M	9,000	16,500		
	H	12,000	25,000		
	W	16,000	30,000		

Clutch Bores

Clutch Size	Bores (inch)	
	Min.	Max. (1)
05	0.6250	2.0000
06	0.6250	2.7500
09	1.0000	4.2500
11	1.0000	4.2500

Refer to Page 96 for a complete list of bore codes.
(1) Square Key

Clutches are shipped set for the minimum torque value of the specified range.

Refer to Page 47 for ordering information.

H1900 Overload Clutches WOR Series

Style A and M Through-Bore Type J Jaw Clutch Adapter

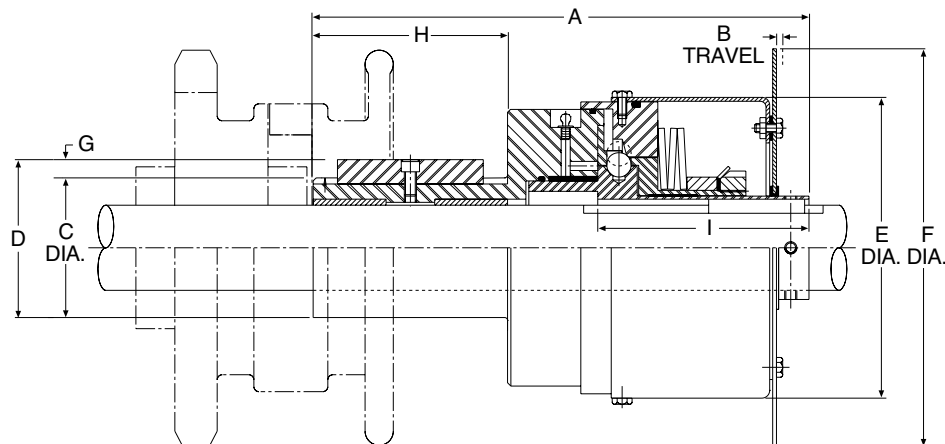

All Dimensions in Inches

Clutch Size	A	B	C	D +0.000/-0.002	E	F	G	H	I
05	10.20	.13	2.875	3.250	6.19	8.19	.38	4.00	4.50
06	12.25	.17	3.500	3.875	7.62	9.62	.38	4.50	5.25
09	14.62	.19	4.000	4.500	9.65	11.62	.50	5.00	6.12
11	15.87	.19	5.000	5.500	9.65	11.62	.50	5.50	7.00

Ratings

Clutch Size	Torque Code	Torque Range (Lb. In.)		Max. RPM	Weight (Lbs.)
		Min.	Max.		
05	L	850	1,700	50	31
	M	1,100	2,200		
	H	1,400	2,800		
	W	2,500	5,000		
06	L	1,250	2,500	50	50
	M	1,800	3,750		
	H	2,500	5,500		
	W	4,000	8,000		
09	L	2,250	5,750	50	96
	M	3,750	8,500		
	H	5,500	12,000		
	W	8,500	20,000		
11	L	5,000	12,000	50	119
	M	9,000	16,500		
	H	12,000	25,000		
	W	16,000	30,000		

Clutch Bores

Clutch Size	Bores (inch)		
	Min.	Max. (1)	Max. (2)
05	0.6250	1.6250	1.7500
06	0.6250	2.1250	2.2500
09	1.0000	2.7500	3.0000
11	1.0000	3.7500	4.0000

Refer to Page 96 for a complete list of bore codes.

- (1) Square Key
- (2) Flat Key

Clutches are shipped set for the minimum torque value of the specified range.

Refer to Page 47 for ordering information.

Limit Switch Layout

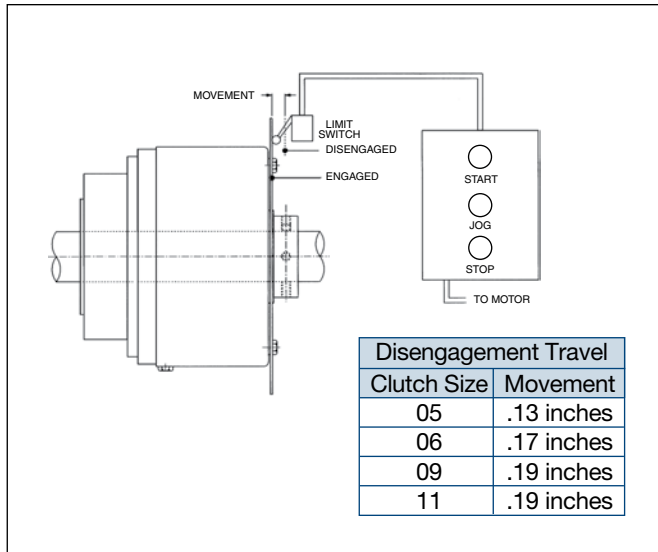

Figure 6

Torque Overload Detection

The WOR Series H1900 is offered with an automatic reset (Style A/B). Because of this feature, it is important that the drive be shut down immediately upon a torque overload condition. Figure 6 utilizes a single limit switch to detect an overload. The switch should be able to operate within the disengagement travel of the clutch. Upon an overload, an oversized stainless steel plate attached to the cover will move to actuate the limit switch and shut down the drive.

Torque Adjustment Wrench

Standard bearing nuts are used to adjust the spring load which controls the release torque of the clutch. These nuts are slotted and can easily be turned using a common, commercially available hook style spanner wrench. Refer to the table at bottom of this page for wrenches which are compatible with Boston Gear's torque overload release clutches.

Suggested Specifications for Water and Wastewater Treatment Applications

Overload release clutches shall be installed to provide positive protection against damaging jams to the drives. They are to be located on the output sides of speed reducers, or as near as possible to the potential source of the overload so that the drive components are adequately protected.

The clutches shall be a ball detent type which when an overload occurs, the detent balls will roll free from their seat against pre-set spring pressure, completely disengaging the drive. Springs are to be a precision Belleville design conforming to spec. DIN-2092 and DIN-2093.

Resetting shall be a simple manual push back re-engagement (or automatic reset) and torque values will remain constant within plus or minus 10% after each disengagement or re-engagement.

All clutches shall be fully adjustable through a wide torque range to meet varying conditions and include a maximum torque limit stop to prevent adjustment beyond designed torque values. A circular plate is to be incorporated in the cover as a means to operate a limit switch to annunciate and/or stop the drive.

The clutches shall be completely sealed suitable for outdoor installations, including a stainless steel cover, electroless nickel plated external parts, and an external grease fitting for packing the units.

Chrome alloy steel detent balls shall be hardened to 60 Rc and all major internal components hardened to 50 Rc minimum for long life.

The WOR Series H1900 Overload Release Clutches shall be manufactured by Boston Gear, Charlotte, North Carolina 28216.

Torque Adjustment Wrench

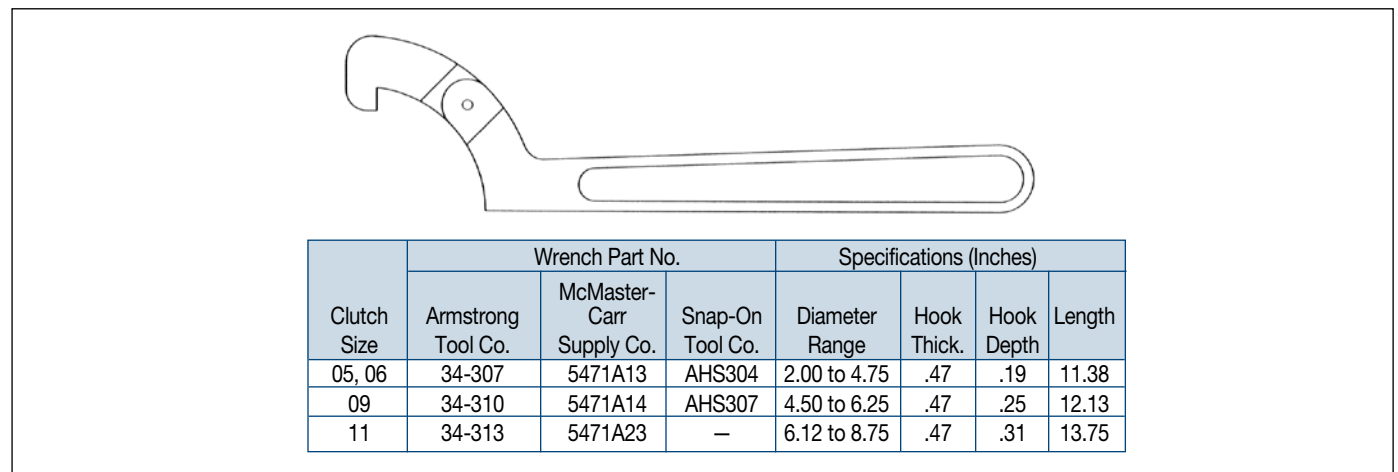

H1900 Overload Clutches

Torque Limiter Application Data

Fax To 800-816-5608

Please select your product intent below and provide as much application information as possible.

1. Application:

- New
- Existing
- Replacement Model # _____

2. Power transmission requirements at clutch location:

- RPM _____
- Limiting Torque Level _____

3. Type:

- Mechanical (Spring Loaded)
- Pneumatic

4. Type:

- Fully Automatic Re-Engagement
- Manual (Free Wheeling)
- Semi Automatic (ORC model only)

5. Method of Torque Transmission:

- Flexible Coupling
 - Rigid Coupling
 - Sprocket Mount
- Sprocket Size and Tooth Count _____

6. Bore Size:

- Sprocket Mount (Clutch Bore) _____
- Coupling Mount (Clutch Bore) _____
(Coupling Bore) _____

7. Shut Down Method:

- Prox Plate
- Pin Style (ORC only)
- None Required

Name: _____

Phone # _____

Fax # _____

Company _____

E-Mail _____

Use the space below to note any relevant application data or to detail your question.
